

**Description**

The AZBDC10A4IC interface card and PWM servo drive assembly is designed to drive brushless and brushed DC motors at a high switching frequency. The interface card features quick-disconnect connectors. A DIP Switch is available to switch between brushless and brushed motors. The AZBDC10A4IC is fully protected against over-voltage, under-voltage, over-current, over-heating, and short-circuits. A single digital output indicates operating status. The drive interfaces with digital controllers that have digital PWM output. The PWM IN duty cycle determines the output current and DIR input determines the direction of rotation. This servo drive requires only a single unregulated isolated DC power supply, and is fully RoHS II (Reduction of Hazardous Substances) compliant. Easily accessible test points are available for I/O and Feedback monitoring.

See Part Numbering Information on last page of datasheet for additional ordering options. The AZ Series Hardware Installation Manual is available for download at [www.a-m-c.com](http://www.a-m-c.com).

**Power Range**

Peak Current	10 A
Continuous Current	5 A
Supply Voltage	10 - 36 VDC

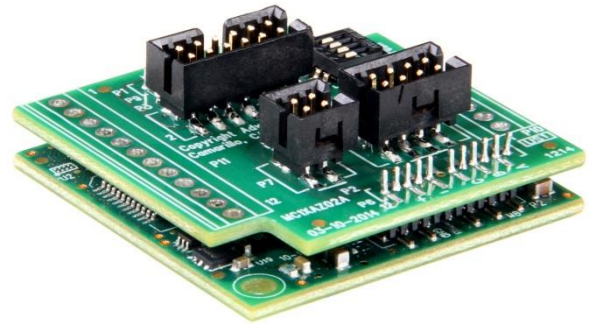

**Features**

- ▲ Detachable Connectors
- ▲ Four Quadrant Regenerative Operation
- ▲ Direct Board-to-Board Integration
- ▲ Lightweight
- ▲ High Switching Frequency
- ▲ Wide Temperature Range
- ▲ Differential Input Command
- ▲ Digital Fault Output Monitor
- ▲ Current Monitor Output
- ▲ Single Supply Operation
- ▲ Compact Size
- ▲ High Power Density
- ▲ 12VDC Operation

**HARDWARE PROTECTION**

- Over-Voltage
- Under-Voltage
- Over-Current
- Over-Temperature
- Short-circuit (phase-phase)
- Short-circuit (phase-ground)

**INPUTS/OUTPUTS**

- Digital Fault Output
- Digital Inhibit Input
- Analog Current Monitor
- Analog Command Input

**FEEDBACK SUPPORTED**

- Hall Sensors

**MODES OF OPERATION**

- Current

**COMMUTATION**

- Trapezoidal

**MOTORS SUPPORTED**

- Three Phase (Brushless)
- Single Phase (Brushed, Voice Coil, Inductive Load)

**COMMAND SOURCE**

- PWM

**COMPLIANCES & AGENCY APPROVALS**

- RoHS II
- UL/cUL Pending
- CE Pending

**BLOCK DIAGRAM**

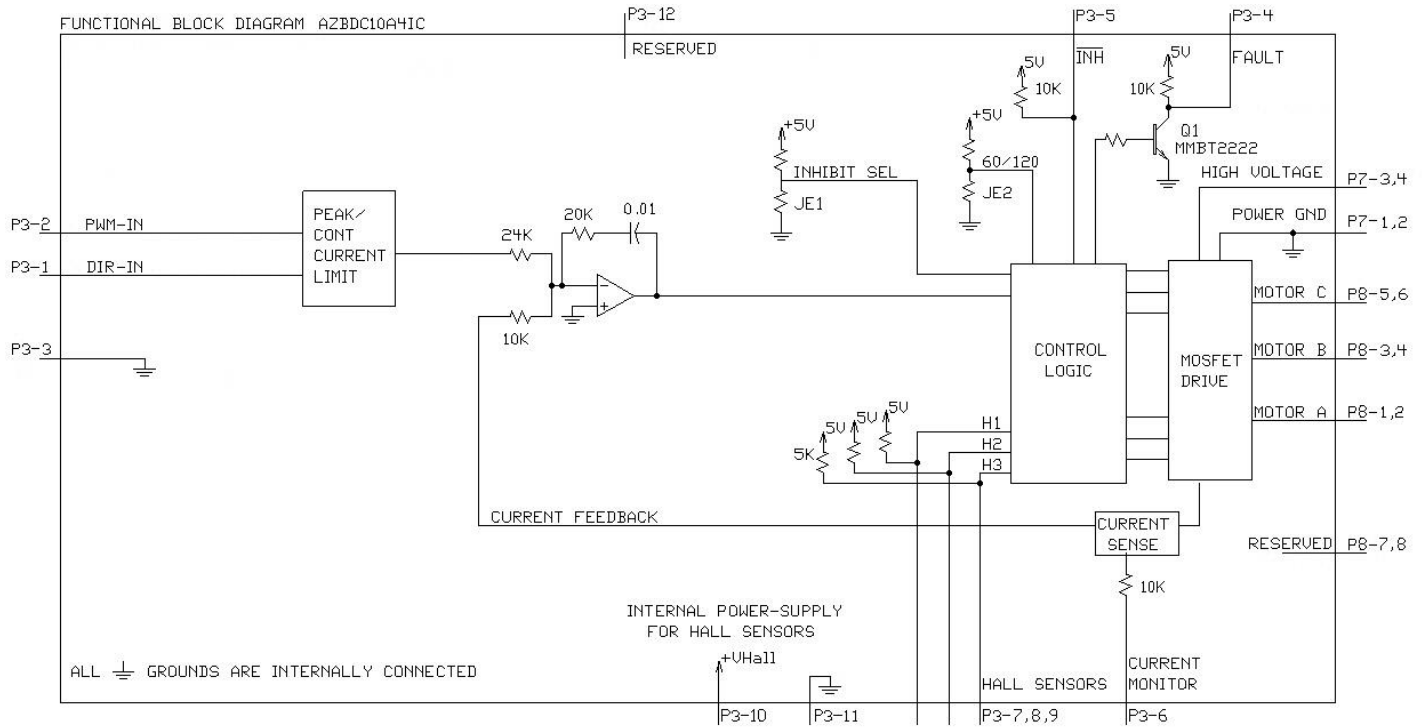

**Information on Approvals and Compliances**



The RoHS II Directive 2011/65/EU restricts the use of certain substances including lead, mercury, cadmium, hexavalent chromium and halogenated flame retardants PBB and PBDE in electronic equipment.

**SPECIFICATIONS**

Power Specifications		
Description	Units	Value
DC Supply Voltage Range	VDC	10 - 36
DC Bus Under Voltage Limit	VDC	8
DC Bus Over Voltage Limit	VDC	40
Maximum Peak Output Current <sup>1</sup>	A	10
Maximum Continuous Output Current	A	5
Maximum Continuous Output Power	W	171
Maximum Power Dissipation at Continuous Current	W	9
Minimum Load Inductance (Line-To-Line) <sup>2</sup>	μH	100
Internal Bus Capacitance	μF	56.5
Low Voltage Supply Outputs	-	+5 VDC (30 mA)
Switching Frequency	kHz	40
Control Specifications		
Description	Units	Value
Command Sources	-	PWM
PWM Input Frequency Range	-	10 - 25
Feedback Supported	-	Halls
Commutation Methods	-	Trapezoidal
Modes of Operation	-	Current
Motors Supported	-	Three Phase (Brushless), Single Phase (Brushed, Voice Coil, Inductive Load)
Hardware Protection	-	Invalid Commutation Feedback, Over Current, Over Temperature, Over Voltage, Under Voltage, Short Circuit (Phase-Phase & Phase-Ground)
Mechanical Specifications		
Description	Units	Value
Agency Approvals	-	RoHS II, UL/cUL Pending, CE Pending
Size (H x W x D)	mm (in)	38.1 x 38.1 x 16.6 (1.50 x 1.50 x 0.65)
Weight	g (oz)	17 (0.6)
Operating Temperature Range <sup>3</sup>	°C (°F)	0 - 85 (32 - 185)
Storage Temperature Range	°C (°F)	-40 - 85 (-40 - 185)
Relative Humidity	-	0 - 90% Non-Condensing
Form Factor	-	PCB Mounted
P3 Connector	-	12-port, 2.0 mm spaced header, vertical mount
P7 Connector	-	4-port, 2.0 mm spaced header, vertical mount
P8 Connector	-	8-port, 2.0 mm spaced header, vertical mount

**Notes**

1. Maximum duration of peak current is ~2 seconds. Peak RMS value must not exceed continuous current rating of the drive.
2. Lower inductance is acceptable for bus voltages well below maximum. Use external inductance to meet requirements.
3. Additional cooling and/or heatsink may be required to achieve rated performance.

## PIN FUNCTIONS

P3 - Signal Connector			
Pin	Name	Description / Notes	I/O
1	DIRECTION	Direction Input (+5V)	I
2	PWM / IN	10 – 25 kHz pulse width modulated digital input command (+5V). Input duty cycle commands the output current.	I
3	SIGNAL GND	Signal Ground (Common With Power Ground).	GND
4	FAULT OUT	TTL level (+5 V) output becomes high when power devices are disabled due to at least one of the following conditions: invalid Hall state, output short circuit, over voltage, over temperature, power-up reset.	O
5	INHIBIT IN	TTL level (+5 V) inhibit/enable input. Leave open to enable drive. Pull to ground to inhibit drive. Inhibit turns off all power devices. For reverse inhibit logic, use –INV ordering option.	I
6	CURRENT MONITOR	Current Monitor. Analog output signal proportional to the actual current output. Scaling is 2 A/V. Measure relative to signal ground.	O
7	HALL 3	Single-ended Hall/Commutation Sensor Inputs (+5 V logic level)	I
8	HALL 2		I
9	HALL 1		I
10	+V HALL OUT	Low Power Supply For Hall Sensors (+5 V @ 30 mA). Referenced to signal ground. Short circuit protected.	O
11	SIGNAL GND	Signal Ground (Common With Power Ground).	GND
12	RESERVED	Reserved	-

P7 - Power Connector			
Pin	Name	Description / Notes	I/O
1	PWR GND	Power Ground (Common With Signal Ground). 3A Continuous Current Rating Per Pin	GND
2	PWR GND		GND
3	HV IN	DC Power Input. 3A Continuous Current Rating Per Pin. Requires a minimum of 47 $\mu$ F external capacitance between HV IN and PWR GND pins.	I
4	HV IN		I

P8 – Motor Power Connector			
Pin	Name	Description / Notes	I/O
1	MOTOR A	Motor Phase Outputs*. Current output distributed equally across 2 pins per motor phase, 3A continuous current carrying capacity per pin.	O
2	MOTOR A		O
3	MOTOR B		O
4	MOTOR B		O
5	MOTOR C		O
6	MOTOR C		O
7	RESERVED	Reserved	-
8	RESERVED		-

\*For use with Single Phase (Brushed) motors, set Switch 1 to ON (see Hardware Settings below) and only connect motor leads to Motor A and Motor B.

## HARDWARE SETTINGS

### DIP Switch Settings

When set to the ON position, DIP Switch SW1 internally shorts Hall 2 to ground for use with single phase (brushed) motors. Note that in this configuration, all Hall signal pins should be left open, and only motor phase outputs A and B should be used. Default switch setting is OFF (three phase / brushless motors).

DIP Switches SW2, SW3, SW4 are reserved.

**MECHANICAL INFORMATION**

**P3 – I/O Connector**

Connector Information	12-port, 2.0 mm spaced header, vertical mount	
Mating Connector	Details	Molex: P/N 51110-1260 (housing) ; 50394-8051 (crimp pins)
	Included with Drive	Yes

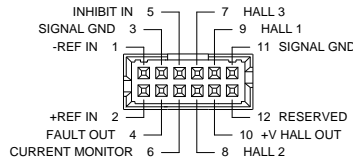

**P7 – Power Connector**

Connector Information	4-port, 2.0 mm spaced header, vertical mount	
Mating Connector	Details	Molex: P/N 51110-0460 (housing) ; 50394-8051 (crimp pins)
	Included with Drive	Yes

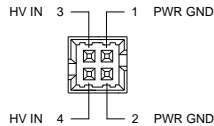

**P8 – Motor Power Connector**

Connector Information	8-port, 2.0 mm spaced header, vertical mount	
Mating Connector	Details	Molex: P/N 51110-0860 (housing) ; 50394-8051 (crimp pins)
	Included with Drive	Yes

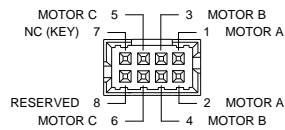

**MOUNTING DIMENSIONS**

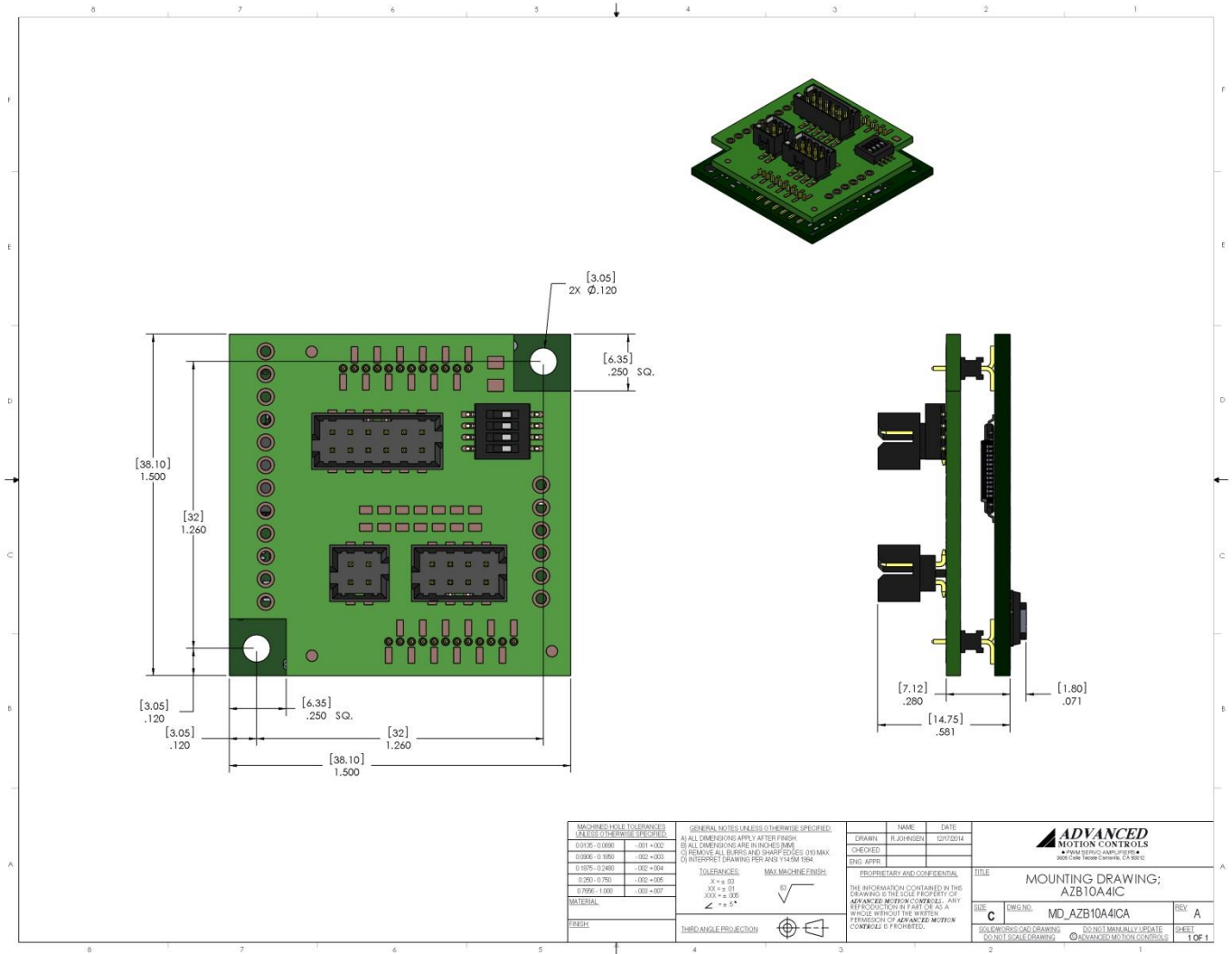

MACHINED HOLE TOLERANCES UNLESS OTHERWISE SPECIFIED: 0.015 - 0.000 -01 +0.02 0.000 - 0.100 -02 +0.03 0.100 - 0.240 -03 +0.04 0.250 - 0.750 -04 +0.06 0.750 - 1.000 -05 +0.07	GENERAL NOTES UNLESS OTHERWISE SPECIFIED: A) ALL DIMENSIONS APPLY AFTER FINISH. B) ALL DIMENSIONS ARE IN INCHES/MM. C) REMOVE ALL BURRS AND SHARP EDGES (0.0 MAX). D) INTERPRET DRAWING PER ANSI Y14.5M 1984.	NAME: R. JOHNSON DATE: 12/17/2014	 3805 Calle Tecate, Camarillo, CA 93012										
TOLERANCES: F = ± 0.1 XX = ± 0.1 XXX = ± 0.05 Z = ± 0.5*	MAX MACHINE FINISH √	PROPRIETARY AND CONFIDENTIAL THE INFORMATION CONTAINED IN THIS DRAWING IS THE SOLE PROPERTY OF ADVANCED MOTION CONTROLS. ANY REPRODUCTION OR PARTIAL USE AS A WHOLE WITHOUT THE WRITTEN PERMISSION OF ADVANCED MOTION CONTROLS IS PROHIBITED.											
MATERIAL: FR-4	THIS ANGLE PROJECTION	<table border="1"> <tr> <th>SIZE</th> <th>DRG NO.</th> <th>REV.</th> </tr> <tr> <td>C</td> <td>MD_AZB10A4ICA</td> <td>A</td> </tr> </table>	SIZE	DRG NO.	REV.	C	MD_AZB10A4ICA	A	<b>TITLE</b> MOUNTING DRAWING; AZB10A4IC <table border="1"> <tr> <td>SOLD UNLESS SO CALLED DRAWING (DO NOT SCALE DRAWING)</td> <td>DO NOT MANUALLY UPDATE</td> </tr> <tr> <td>© ADVANCED MOTION CONTROLS</td> <td>1 OF 1</td> </tr> </table>	SOLD UNLESS SO CALLED DRAWING (DO NOT SCALE DRAWING)	DO NOT MANUALLY UPDATE	© ADVANCED MOTION CONTROLS	1 OF 1
SIZE	DRG NO.	REV.											
C	MD_AZB10A4ICA	A											
SOLD UNLESS SO CALLED DRAWING (DO NOT SCALE DRAWING)	DO NOT MANUALLY UPDATE												
© ADVANCED MOTION CONTROLS	1 OF 1												

**PART NUMBERING INFORMATION**

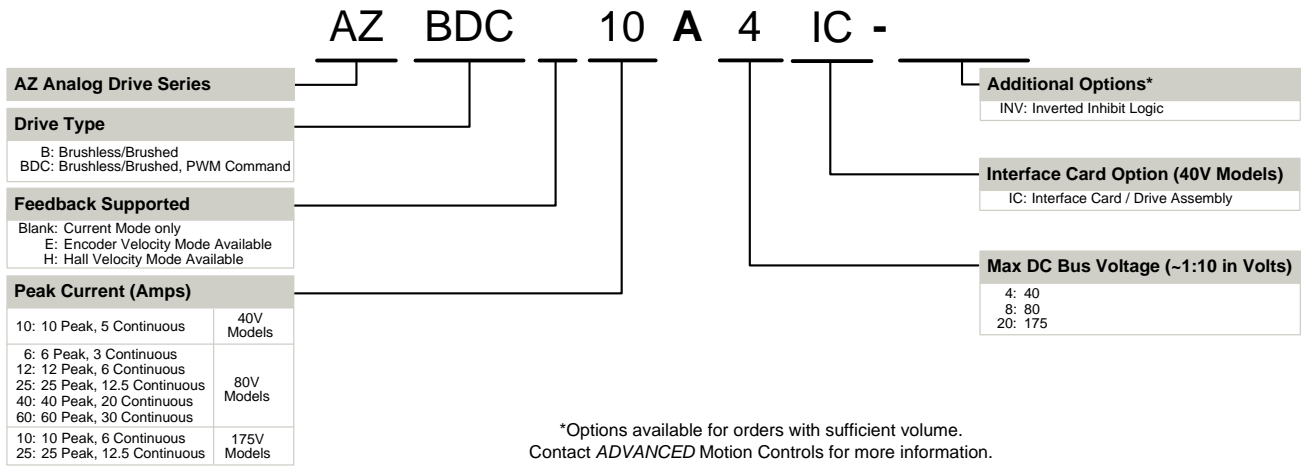

*ADVANCED* Motion Controls AZ series of servo drives are available in many configurations. Note that not all possible part number combinations are offered as standard drives. All models listed in the selection tables of the website are readily available, standard product offerings.

*ADVANCED* Motion Controls also has the capability to promptly develop and deliver specified products for OEMs with volume requests. Our Applications and Engineering Departments will work closely with your design team through all stages of development in order to provide the best servo drive solution for your system. Equipped with on-site manufacturing for quick-turn customs capabilities, *ADVANCED* Motion Controls utilizes our years of engineering and manufacturing expertise to decrease your costs and time-to-market while increasing system quality and reliability.

**Examples of Modifications and Customized Products**

- |   |  |
|---|--|
| <ul style="list-style-type: none"> <li>▲ Integration of Drive into Motor Housing</li> <li>▲ Mount OEM PCB onto Drive Without Cables</li> <li>▲ Multi-axis Configuration for Compact System</li> <li>▲ Custom PCB and Baseplate for Optimized Footprint</li> <li>▲ RTV/Epoxy Components for High Vibration</li> <li>▲ OEM Specified Connectors for Instant Compatibility</li> <li>▲ OEM Specified Silkscreen for Custom Appearance</li> <li>▲ Increased Thermal Limits for High Temp. Operation</li> </ul> | <ul style="list-style-type: none"> <li>▲ Integrate OEM Circuitry onto Drive PCB</li> <li>▲ Custom Control Loop Tuned to Motor Characteristics</li> <li>▲ Custom I/O Interface for System Compatibility</li> <li>▲ Preset Switches and Pots to Reduce User Setup</li> <li>▲ Optimized Switching Frequency</li> <li>▲ Ramped Velocity Command for Smooth Acceleration</li> <li>▲ Remove Unused Features to Reduce OEM Cost</li> <li>▲ Application Specific Current and Voltage Limits</li> </ul> |
|---|--|

Feel free to contact Applications Engineering for further information and details.

**Available Accessories**

*ADVANCED* Motion Controls offers a variety of accessories designed to facilitate drive integration into a servo system. Visit [www.a-m-c.com](http://www.a-m-c.com) to see which accessories will assist with your application design and implementation.

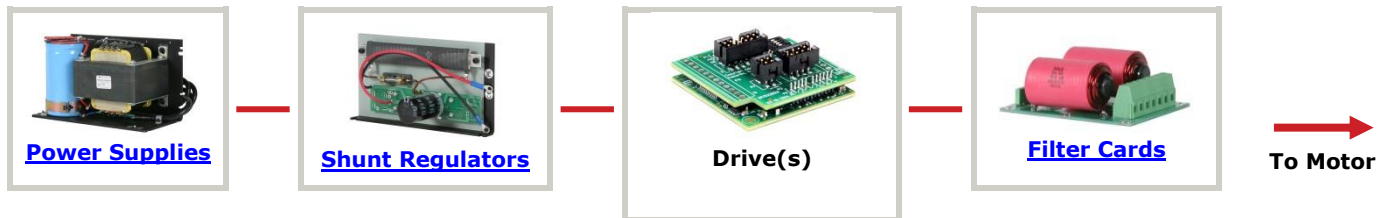

All specifications in this document are subject to change without written notice. Actual product may differ from pictures provided in this document.